

Media Information



FOR IMMEDIATE RELEASE
DATE: Monday, December 3, 2007

AUDI OF AMERICA, INC.
3800 Hamlin Road
Auburn Hills, MI 48326
Tel. 248/754-5000
Fax. 248/754-6140
www.media.audiusa.com

CONTACT: Jeff Kuhlman
(248) 754-6017
jeff.kuhlman@audi.com

Christian Bokich
(248) 754-4729
christian.bokich@audi.com

THE 2008 AUDI A4 AND S4 CABRIOLET: OPEN-AIR LUXURY IN A VERY SLEEK PACKAGE

AUBURN HILLS, Mich. - An enjoyable and sporty driving experience, superior and complex technology, classic and exciting styling, and luxury that those demands make on the luxury class: Audi presents a modern-day classic – the A4 and S4 Cabriolet.

The classic soft-top convertible traits are evident at first glance: the open-top four-seater has Audi's single-frame grille that typifies the brand. The car's taut styling, clear surfaces and tension-packed shoulder line extending along the entire body are characteristic features of the A4/S4 Cabriolet.

The car's technology lives up to the promise made by its styling. The A4 Cabriolet is available with two engines that offer the latest in fuel-injection technology – Audi's FSI. FSI direct-injection represents the most advanced state-of-the-art technology for gasoline engines. The sporty yet comfortable dynamic suspension converts the power delivered by these units into sheer driving pleasure – on every bend, on every mile of the journey.

(more)

Innovative and highly sophisticated technologies are an integral part of practically all vehicle areas and components: the Bi-Xenon headlights with adaptive lighting are proof of this, as is quattro[®] permanent four-wheel drive.

The quality of materials and workmanship in the interior are of a standard that needs not fear comparison with the luxury class. The architecture of the driver's area, especially the cockpit – a perfect synthesis of ergonomics, function and design – is pioneering.

The design

Self-assured in appearance, the striking single-frame grille and clear-glass headlights with their curving, emotional line give the Audi A4 Cabriolet an aggressive face. The trapezoidal shape of the single-frame grille is continued in the more prominent contours of the engine hood.

Like the S4 sedan, the S4 Cabriolet features the S-specific grid pattern in the single-frame grille. The bumpers with large air inlets, the aluminium-look casings for the exterior mirrors, the redesigned rear lights, the V8 badges on the front fenders, and the four oval tailpipes are the distinguishing visual features of the S4 Cabriolet.

Taut lines and clear surfaces that hold no secrets, coupled with a tension-packed shoulder line extending along the entire length of the body, produce a look that is simultaneously powerful and elegant. The rear end is distinguished by lights with a clear-glass appearance that also emphasize the Cabriolet's premium quality from behind. The rear diffuser underscores the car's sports character.

The modern and innovatively designed interior fits with the progressive look of the car's exterior styling. The steering wheels provide their characteristic element in the airbag cover with its single-frame design. Door sill trims with aluminum inserts and numerous aluminum inlays are a standard feature of the A4 and S4 Cabriolet.

(more)

Inside, the S4 Cabriolet differs in appearance from its A4 brother. The instrument cluster has special needles and grey dials that are characteristic of S models. Power adjustable sports seats with leather upholstery further differentiate the S4 Cabriolet.

Inlays in Walnut or Fine Grain Birch wood grey can be ordered. These are attributes that also emphasize the special exclusiveness and elegance of the interior of current A4 models.

Almost all convertibles look good with the top down, but only a few are equally as attractive with the top up. The Audi A4 Cabriolet cuts an extremely fine figure, both open and closed. Thanks to its good thermal insulation and glass rear window, the Audi A4/S4 Cabriolet also can be used without restriction in the winter.

Audi also offers an acoustic roof that is even more insulating. By using new fabrics with a greater material density, the noise level inside the cabin is reduced further, virtually matching that of the A4 sedan, even at highway speeds. This new acoustic top is standard fare on the S4 Cabriolet.

Engines and transmissions

The A4 Cabriolet is offered with two highly modern engines with FSI gasoline direct injection: the 3.2 FSI V6 and the two-liter four-cylinder 2.0 TFSI. They combine high performance with a spontaneous response to every movement of the accelerator pedal and a peak-torque range at a high level.

The 3.2 FSI V6 produces 255 hp at 6,500 rpm and 243 ft. lbs. of torque at 3,250 rpm. About 90 percent of the engine's peak torque is available from 1,900 to 5,900 rpm, allowing for strong acceleration in any gear, at any speed.

At its launch the 2.0 TFSI four-cylinder was the first engine to combine turbo charging and direct gasoline injection. Producing 200 hp from 5,100 to 6,000 rpm and 207 ft. lbs. of torque between 1,800 to 5,000 rpm, the 2.0 TFSI is a marvel of power and efficiency.

(more)

The Audi S4 Cabriolet is propelled by a 340 hp eight-cylinder engine. Its maximum power output is reached at 7,000 rpm. The 4.2-litre engine delivers a hefty 302 ft. lbs. of torque at 3,500 rpm. Thanks to such a superior power flow from the substantial displacement, this naturally aspirated engine exhibits an air of supreme confidence.

All three engines have been named to recent *Ward's 10 Best Engines* lists, a further testament to their advanced design and abilities.

These three engines deliver their power to the road either via the front wheels or by means of quattro permanent four-wheel drive. Customers can choose from a continuously variable Multitronic transmission (2.0 TFSI FrontTrak), a six-speed manual with a 40:60 front to rear torque split (S4), and a six-speed Tiptronic automatic transmission (standard 2.0TFSI quattro and 3.2, option on S4).

The chassis

The set-up of the dynamic suspension system, with four-link front and self-tracking trapezoidal-link rear suspension, has been designed for sporty handling and good ride comfort.

The steering has been developed to give the driver greater precision, as well as better feedback from the road when cruising. In connection with this, the engineers adopted several mountings and the dimensions of the front and rear shock absorbers from the Audi A6. The rear trapezoidal links and the front track rods originate from the S4 sedan.

These systems add up to a high level of agility and precise handling, combined with first-class ride comfort – all qualities that benefit drivers of the Audi A4 Cabriolet. This also applies to the brakes, whose dimensions and performance have been adapted to suit the Cabriolet.

(more)

Equipment and trim

The Audi A4/S4 Cabriolets offer a standard equipment list that sets a benchmark in the midsize class. Every new A4 Cabriolet, for example, comes with a power retractable roof and dual-zone automatic climate control, ten-speaker audio system with in-dash six-CD changer and MP3 compatibility, power one-touch windows, driver information display, cruise control, large ski sack, high-pressure headlight washer system, and numerous other features that are typical of a luxury convertible.

All A4 Cabriolet models can be equipped with an optional S line package consisting of five-spoke 18" alloy wheels designed by quattro GmbH with performance or all-season tires, sport suspension, S line front and rear bumpers, and brushed aluminum interior trim.

Both the A4 and S4 Cabriolets can be equipped with an Audio package with a Bose premium sound system and SIRIUS satellite radio, and a Convenience package including HomeLink, auto-dimming exterior and interior mirrors, light/rain sensor for automatic wipers and headlights, Bi-Xenon headlights (standard on S4) with adaptive front technology, driver side memory for seat and mirrors, heated front seats (S4 only), and acoustic convertible top (on 3.2 models only; standard on S4).

Other stand alone options on the A4 and S4 Cabriolet consist of luxury items like heated front seats, Audi Navigation Plus, and Bluetooth phone preparation.

Safety is standard, not optional

The Audi A4/S4 Cabriolet's A-pillars are reinforced very effectively by means of high-strength tubes whose structure is an indispensable source of extra safety if the car rolls over. Sills with an optimized thickness and cross-section boost the occupant cell's strength and occupant protection. High-strength tubes also are used in the seat structure, as a means of protecting the occupants in the event of a lateral collision.

(more)

The doors, in particular, have to be designed with safety in mind. In conjunction with structural reinforcements in the sills and a strengthening cross-member below the rear seat, special impact absorbing beams in the doors help ensure a high standard of safety. At the back of the car, a double rear panel improves body rigidity.

The comprehensive safety package contains seat belts with belt-force limiter and belt tensioner for all passengers, together with full-size front and side airbags. The side airbags integrated into the front seats are designed to protect the head and thorax.

If the car rolls over, a roll-over protection system in the double rear bulkhead adds to the occupants' safety. In this case, two protective bars, controlled by sensors, are triggered behind the rear passengers within milliseconds. Together with the extremely rigid windshield frame, they help to preserve survival space for all occupants if the car turns over.

The standard electronic stabilization program ESP 8.0 with hydraulic brake assist provides for maximum active safety.

All seats are equipped with three-point inertia-reel belts (the front belts have belt-force limiters and belt tensioners, plus a seat belt reminder for the driver) and head restraints. The safety equipment specification also includes a driver's airbag activated in two stages and side airbags.

Warranty

The Audi A4 and S4 Cabriolet will be backed by a new vehicle limited warranty that includes:

- Four-year/50,000 mile limited new vehicle warranty
- 12-year limited warranty against corrosion perforation
- 24-hour Roadside Assistance for four years

(more)

About Audi of America

Audi of America, Inc., currently offers a line of luxury vehicles that includes the Audi A3 sport compact; the sporty A4 and S4 sedan, Avant, and Cabriolet models; the high-performance RS 4 sports sedan and Cabriolet; the all-new S5 coupe with a 354-horsepower engine; the A6 sedan and Avant; the V10-powered high-performance S6 sedan; the newly updated flagship A8 and S8 luxury sedans available with 8, 10, and 12 cylinders; the Audi Q7 performance SUV; the all-new for 2008 TT Coupe and Roadster models; and the all-aluminum R8 mid-engine supercar, one of the most exclusive sportscars in the world. Audi's 270 dealers sold 90,116 vehicles in the United States during 2006. Information regarding the Audi brand and products can be found at www.audiusa.com, and information for media can be found at www.media.audiusa.com.

#

*“quattro,” “multitronic,” and “FrontTrak” are registered trademarks of Audi AG.
All other trademarks used in this document are the property of their respective owners*



Legend		S4 Cabriolet
x = Standard	o = Optional	- = Not available
General Technical		
• 4.2 liter 340 hp DOHC 5-valve V8 engine with two-stage variable intake manifold		x
• LEV2 (Low Emission Vehicle) certification		x
• 6-speed manual transmission with synchronized reverse gear; dual mass flywheel		x
• 6-speed automatic transmission with Tiptronic® (allowing driver to select gears manually) and Dynamic Shift Program (DSP) which selects from over 200 shift programs to match driver needs. Transmission also includes hill detection capability		o
• Four-wheel Anti-lock Brake System (ABS) with Electronic Brake pressure Distribution (EBD)		x
• Brake Assist, a system which automatically senses emergency braking and applies maximum available power boost to reduce overall stopping distance		x
• "quattro" - permanent all-wheel drive system, includes Torsen® torque sensing center diff. (S4 Tiptronic)		o
• "quattro" - permanent all-wheel drive system, includes "Torsen® C" 40/60 torque split (S4 manual)		x
• Fully galvanized sheet metal		x
• CAN network, including 3 fully functional CAN circuits (Infotainment / Comfort / Powertrain)		x
• ESP (Electronic Stabilization Program), version 5.7. System also includes ABS / EBD / EDL / ASR		x
• CFC-free (chloroflourocarbon) air conditioning refrigerant		x
• Fully automatic aluminum & steel convertible Acoustic soft top with optimized noise and temperature insulation and heated glass rear window		x
Wheels / Tires		
• 8J x 18 ET 43 7-double spoke design cast alloy wheels with 235/40 high-performance tires		x
• Full size spare tire with matching alloy wheel		x
Suspension / Steering / Brakes		
• Front ventilated disc brakes, (FNRG-60), 345mm x 30mm rotors		x
• Rear ventilated disc brakes (C43HR), 302mm x 22mm rotors		x
• Four-wheel Anti-lock Brake System (ABS) with Electronic Brake pressure Distribution (EBD)		x
• Brake Assist, a system which automatically senses emergency braking and applies maximum available power boost to reduce overall stopping distance		x
• "S4" tuned Sport suspension, including stiffer shocks / springs, stronger stabilizer bars in front / rear, suspension lowered by 30 mm		x
• Four-link front suspension with high aluminum content including forged aluminum upright		x
• Trapezoidal link, fully independent rear suspension		x
• Servotronic, speed-sensitive close ratio power steering for more sporty driving/handling		x
• Tilt and telescopic manually adjustable steering column		x
Exterior Features		
• 5 MPH (Federal standard) front and rear bumpers		x
• Remote release Tank Lid (fueling area continues to be on rear passenger side)		x
• Retractable high pressure headlight washers concealed in the front bumper		x
• Heated windshield washer nozzles		x
• Satellite radio preparation, including concealed under-trunk antenna able to receive signals from Sirius satellite radio		x
• Concealed antenna system (GPS, Satellite and AM/FM/Satellite radio prep) via composite material trunklid		x
• Distinctive S4 exterior mirror housings, left side flat, right side convex		x
• Metallic / Pearl Effect paint		o
• Nomenclature:		x
- S4 on rear deck lid, left center		x
- S4 on right side of upper front grille		x
- Four rings on top center of rear deck lid		x
- Four rings on top center of front grille		x
- 85 mm quattro badge on dashboard belt line trim		x
- V8 badge on side blinker indicator lights		x
Exterior Lighting		
• Bi-Xenon headlights with automatic self-leveling		x
• Adaptive Front Lighting System (pivots with steering wheel direction at certain speeds)		o
• Two front fog lights located in lower front bumper		x
• Rear light assemblies with white side turn indicators and red shine-through bulbs		x
• Daytime running lights utilizing front fog lights (USA: programmable with bi-xenon, std in Canada)		x
• White side turn indicator lights in front fenders with amber shine-through bulbs		x



Legend		S4 Cabriolet
x = Standard	o = Optional	- = Not available
Comfort / Convenience		
• Fully automatic dual-zone climate control system with seven temperature sensors, sun sensor and pressure sensor. Also includes active charcoal and electrostatic filters, which sense pollen, odors, bacteria and dust.		x
• Light sensor: operated by pulling right-hand windshield wiper stalk up one notch into intermittent mode; sensitivity also adjustable within stalk		o
• HomeLink® universal garage door opener in driver's sunvisor		o
• Light Sensor: operated by adjusting exterior light switch to "Auto"; system senses the intensity of sunlight		o
• Front and rear power windows with:		x
- pwr retention feature, which keeps pwr for windows and sunroof on until either front door opens		
- "pinch protection" for all 4 windows that reverses window at force of 100 N or greater		
- "one-touch" individual up and down function for front and rear window controls at all window locations		
- master switch that retracts all windows at the same time		
- windows automatically lower a few millimeters when either front door opens		
• Electronic cruise control with coast, resume, speed up & down, controlled by a lever on left side of steering wheel; cruise control indicator located in the instrument panel		x
• Auto-Blink feature enables turn signals to automatically blink three times when blinker lever briefly pushed up/down (common when changing lane)		x
• Power central locking system (doors, deck lid and fuel door) with selective unlocking (enables unlocking of a single front door or all doors), plus:		x
- convenience open and close feature for windows & convertible top (opens / closes all windows and convertible top when key held in driver lock / unlock position)		
- front master switches located in driver and front passenger doors, include LED's to signal when vehicle is locked.		
- rear master switch located in center console, under ashtray. The switch is used for locking all doors. It's a lock-only switch, and it includes LED to signal when the vehicle is locked.		
- central locking can be programmed at any authorized Audi dealer to automatically lock when vehicle reaches 8 MPH. Vehicle then automatically unlocks when key taken out of ignition.		
• Automatically dimming outside mirrors with folding feature		o
• Exterior mirrors: Power folding/auto-dimming/heated/memory - interior controls inside driver door		x
• Four-position driver side memory for seat and mirror adjustments		o
• Electrically adjustable outside rearview mirrors with heating feature. Heating is automatically activated when outside temperature is less than 59 degrees F. When outside temperature reaches 77 degrees F, heating automatically stops.		x
• Illuminated vanity mirrors in left and right front sunvisors		x
• Ski sack		x
• Third, middle sunvisor above rearview mirror		x
• Rear deck lid release with "soft touch" opening feature and remote deck lid release located in driver's door		x
• Extended range (up to 150 ft.) radio frequency remote locking system with security "rolling code" feature, selective unlock, remote trunk opening and panic function, also activates interior lights and alarm system - all integrated in folding key		x
• Interior lights in front with fade-in and fade-out feature, time delay and automatic switch on when key is withdrawn from ignition		x
• Illuminated glove box, rear cargo area, lighter and ashtray		x
Seating		
• 12-way sport power front (driver & passenger) seats including 4-way electric lumbar adjustment and adjustable head restraints		x
• Front seat-back map net pockets		x
• Three 3-point safety belts for all front and rear positions (total of 4)		x
• Heated front seats		x
• 2 adjustable head restraints for rear seats		x

2008 Audi S4 Cabriolet Equipment



Legend		S4 Cabriolet
x = Standard o = Optional - = Not available		
Interior		
•	Genuine Silk Nappa full-leather seat upholstery; door inserts, front / rear center armrest, shift knob and steering wheel in matching leather	x
•	Front and rear floor mats with fastening mechanism	x
•	Genuine gray birch wood trim on dashboard, door panel interior beltline, center console and front / rear ashtrays	o
•	Carbon Fiber trim on dashboard, door panel interior beltline, center console and front / rear ashtrays	o
•	Brushed aluminum interior beltline trim from quattro GmbH	x
•	3-spoke leather wrapped sport steering wheel (with Tiptronic paddle controls on automatic models)	x
•	Leather covered transmission shift knob (automatic models), shift boot (manual models) and hand brake handle (all models)	x
•	Folding front center armrest with adjustable height and dual cupholder	x
•	Automatically dimming interior mirror with digital compass	o
•	Center console: US/Canada specific, full-length, emergency brake lever moved several millimeters toward driver seat to accommodate dual integrated cupholders.	x
	- 12V power outlets (SAE) (1) ashtray in front of rear shift knob, and (2) w/in console	
	- 2 integrated cupholders with spring-loaded size adjustment tabs	
	- Front center armrest	
	- Front and rear ashtray	
	- Storage area under center armrest	
•	Fold down rear center armrest with a comprehensive First-aid kit	x
•	Dual rear cupholder located in the rear center armrest	x
•	Protective door sill trim	x
•	Climate control panel (in center console) with integrated heated seat switches (when heated seats ordered)	x
•	Ambient red lighting in headliner for dash and center console	x
•	Illuminated air vent controls in dashboard	x
•	Four tie-down eyelets with luggage net in trunk	x
•	Tool kit located in the spare wheel well	x
Instruments / Electrical equipment		
•	450 A Battery (95 AH)	x
•	Backlit instrument cluster with automatic brightness control including following features:	x
	- sporty, tubular gauge design	
	- white numbering with red pointers, digital clock with date	
	- tachometer, electronic speedometer	
	- fuel gauge, coolant temperature gauge	
	- various additional warning lights	
	- Driver information display (described below)	
•	Digital trip odometer with service interval indicator	x
•	Eight color driver information display including:	x
	- 5-function trip computer (timer / miles-to-empty / average MPG / average MPH / instant MPG)	
	- outside temperature display	
	- radio / telephone / navigation display	
	- Auto Check system which constantly monitors various functions and components within the vehicle, such as battery voltage, brake pad indicator, oil level indicator, washer fluid indicator, and more.	
	- speed warning device	
	- pictogram display for open door and trunk	
•	Concealed headlight washer system, integrated in the front bumper	x
•	Windshield wipers with 4-position adjustable intermittent interval rate	x
•	Heated windshield washer nozzles	x



Legend		S4 Cabriolet
x = Standard o = Optional - = Not available		
Instruments / Electrical equipment continued		
<ul style="list-style-type: none"> Advanced anti-theft vehicle alarm system with following features: <ul style="list-style-type: none"> - theft deterrent light in driver's door - III. Generation Immobilizer prevents engine start when key with automatically changing electronic code feature is not used - back-up horn - tilt sensor which prevents theft by towing; function can be defeated by switch located in driver's door - system automatically arms when vehicle locked 		x
<ul style="list-style-type: none"> Audi Symphony (II+) radio with and without Bose featuring: <ul style="list-style-type: none"> - AM / FM / Sat radio; with preset capability (18 FM/AM, 21 Satellite) - digital AM/FM tuner in combination w/ dual diversity antenna system - in-dash six-disc CD changer with MP3 reading capability - random mode for individual CD's as well as entire CD changer - phase diversity: improved AM and FM reception - RDS (Radio Data System) displays radio station call letters and other information - "Autostore" function which automatically selects the 6 AM and 6 FM strongest stations in the area - theft deterrent design which only fits an Audi vehicle - GALA (Graduated Audio Level Adjustment) varies volume based on vehicle speed; NOTE: deactivated with Bose AudioPilot noise compensation - Satellite radio standard 		x
<ul style="list-style-type: none"> Audi Navigation Plus (with or without Bose): <ul style="list-style-type: none"> - AM/FM/Sat radio bands; 30 combined radio presets - Satellite radio standard - 1 disc DVD to cover all US and Canada - Full color, map-based navigation screen - MMI control logic with similar screen design and font (only controls radio/CD/nav functions) - SD card inserts (2) to store MP3 data (music) to transfer into radio controls - GALA (Graduated Audio Level Adjustment) varies volume based on vehicle speed. Deactivated if equipped with Bose AudioPilot noise compensation feature. - Theft deterrent design to prevent theft - Part of package with glovebox 6-CD changer - LCD screen dimensions: 3 in. vertical; 5.5 in. horizontal; 6.25 in. diagonal - 5 language settings and voice guidance (English/French/Spanish/Italian/German) 		o
<ul style="list-style-type: none"> Rear window defroster. When activated, defroster remains continuously on when outside temperature is 32 degrees F (zero C) or below. When temperature is 33 degrees F or above, function automatically turns off after approx. 10 minutes. 		x
<ul style="list-style-type: none"> CAN network, including 3 fully functional CAN circuits (Infotainment / Comfort / Powertrain) 		x
Safety / Security		
<ul style="list-style-type: none"> Four-wheel Anti-lock Brake System (ABS) with Electronic rear Brake pressure Distribution (EBD) 		x
<ul style="list-style-type: none"> Valet key: cannot open glovebox 		
<ul style="list-style-type: none"> Brake Assist, a system which automatically senses emergency braking and applies maximum available power boost to reduce overall stopping distance 		x
<ul style="list-style-type: none"> Driver and front passenger next generation airbag supplemental restraints with dual threshold deployment determined by seat belt buckle switches 		x
<ul style="list-style-type: none"> Driver and front passenger seat-mounted head/thorax side airbag supplemental restraints 		x
<ul style="list-style-type: none"> Knee airbags for front occupants (standard on all A4/S4 Cabriolets) 		x
<ul style="list-style-type: none"> "Up front" crash sensors (2), which include integrated system of 6 sensors throughout the vehicle which can best determine severity of a crash, and can therefore better deploy technology designed to protect the passengers. 		x
<ul style="list-style-type: none"> Active rollover protection system 		x



Legend		S4 Cabriolet
x = Standard o = Optional - = Not available		
Safety / Security continued		
<ul style="list-style-type: none"> • If crash sensor system is activated, following will happen automatically: <ul style="list-style-type: none"> - central locking automatically unlocks - interior lighting is switched on - fuel pump and engine are switched off - hazard warning lights are switched on • Impact protection, including reinforced high strength steel / aluminum crossmembers, reinforced bumpers, and rigid occupant cell • Side intrusion beams in side doors which ensure equal distribution of forces in case of side impact 	<p>x</p> <p>x</p> <p>x</p>	
<ul style="list-style-type: none"> • Fuel tank within protective bodywork structure with special safety valves which prevent gravitational fuel spillage in case of rollover 	<p>x</p>	
<ul style="list-style-type: none"> • LATCH (Lower Anchors and Tethers for CHildren) seat provisions in rear seats 	<p>x</p>	
<ul style="list-style-type: none"> • Two front head restraints with locking mechanism to keep restraints in place 	<p>x</p>	
<ul style="list-style-type: none"> • Two rear head restraints 	<p>x</p>	
<ul style="list-style-type: none"> • Two front fog lights located in lower front bumper 	<p>x</p>	
<ul style="list-style-type: none"> • Front 3-point safety belts with automatic pretensioning, and belt force limiters 	<p>x</p>	
<ul style="list-style-type: none"> • Two 3-point rear safety belts with automatic pretensioning 	<p>x</p>	
<ul style="list-style-type: none"> • Front passenger and rear safety belts with CLR (Convertible Locking Retractor, a ratcheting mechanism for conveniently securing a child seat) 	<p>x</p>	
<ul style="list-style-type: none"> • Front seats include a high strength steel reinforcement construction to protect from side rear impact; additional protection against loose loads sliding forward during heavy braking 	<p>x</p>	
<ul style="list-style-type: none"> • Seatbelt buckle sensors for front passengers which control airbag deployment based on whether the passenger is restrained 	<p>x</p>	
<ul style="list-style-type: none"> • Auto-Blink feature enables turn signals to automatically blink three times when blinker lever briefly pushed up/down (common when changing lane) 	<p>x</p>	
<ul style="list-style-type: none"> • Tire pressure monitoring system 	<p>x</p>	
<ul style="list-style-type: none"> • Reflectors in rear of all doors 	<p>x</p>	

2008 Audi S4 Cabriolet



Technical Specifications		2007 Audi S4 Cabriolet	
ENGINE:			
Type	V8-arrangement 8-cylinder with Double Overhead Camshafts and two-stage variable intake manifold		
Arrangement	Front mounted		
Bore	3.33 in.	84.5 mm	
Stroke	3.65 in.	92.8 mm	
Displacement	254 cu. in.	4163 cc	
Compression ratio	11.0:1		
Fuel requirement	Premium unleaded 91 AKI / 95 RON recommended for maximum performance		
Horsepower (SAE)	340 hp	@ 7000 (man) rpm	@ 6800 (Tip) rpm
Max. Torque	302 lbs. ft.	@ 3500 rpm	
ENGINE DESIGN:			
Cylinder block			
Crankshaft			
Cylinder head	Aluminum alloy		
Valve train / intake	Intake camshaft adjustment, DOHC belt driven, hydraulic lifters		
Firing order			
Cooling system	Water-cooled, thermostatically controlled radiator fan		
Lubrication system	Gear pump, pressurized, full flow with oil cooler		
Fuel injection / Ignition system	Motronic 7.1.1: fully electronic sequential injection, hot-film air mass measurement, drive-by-wire throttle control, mapped ignition with solid-state high-voltage distribution, cylinder-selective adaptive knock control using four sensors		
Emission system	Two close-coupled primary and two underfloor main catalytic converters; adaptive lambda control with two heated oxygen sensors before and two after the converter.		
ELECTRICAL SYSTEM:			
Battery	12 volts	95 amp/hr	
Alternator	14 volts	190 amp	
DRIVETRAIN:			
Transmissions	<ul style="list-style-type: none"> • 6-speed manual transmission • 6-speed automatic with Tiptronic® 		
Type	quattro Manual 6-speed		Automatic 6-speed w/ Tiptronic®
Gear ratios: 1st	3.667:1		4.171:1
2nd	2.050:1		2.340:1
3rd	1.462:1		1.521:1
4th	1.133:1		1.143:1
5th	0.919:1		0.867:1
6th	0.778:1		0.691:1
Final Drive	3.889:1		3.539:1
Torque Split	40/60		50/50
Front Differential	Hypoid gear, electronically locking (EDL)		
Center Differential	TORSSEN® (TORque SENSing) differential providing automatic and variable front to rear power proportioning		
Rear Differential	Hypoid gear, electronically locking (EDL)		
STEERING:			
Type	Maintenance-free rack-and-pinion steering with power assist		
Ratio	14.5:1		
Turns (lock-to-lock)	n/a		
Turning circle (curb-to-curb)	37.7 ft.	11.5 m	
SUSPENSION:			
Front	Four link, upper and lower control arms, stabilizer bar, coil spring/shock absorbers (gas charged)		
Rear	Fully independent, trapezoidal link rear suspension, stabilizer bar, separate coil springs and shock absorbers (gas charged)		
BRAKES:			
Service brake	Dual circuit brake system with diagonal split, Anti-lock Brake System (ABS), Electronic Brake pressure Distribution (EBD) and Electronic Stabilization Program (ESP); tandem brake booster		
Front, size and type	13.6 in.	345x30 mm	- Ventilated disc / FNRG - 60
Rear, size and type	11.9 in.	302x22 mm	- Ventilated disc / C43 HR
Parking brake	Mechanically actuated at the rear wheels		

2008 Audi S4 Cabriolet



Technical Specifications (continued)		2007 Audi S4 Cabriolet	
CABRIOLET TOP:	Minimum necessary clearance for opening the convertible top is 85 inches / 7 ft. 1 inch.		
WHEELS:	Standard (C5G)		
Size	8J x 18		
Offset	43 mm		
Weight	5.8 lbs		
Type	Cast alloy		
TIRES:			
Size	235/40		
Speed rating	Z		
Construction	Radial		
Load Index	91		
Brand / Type (all approved)	Conti Sport Contact 2		
BODY:			
Material	Unitized steel structure with integrated aluminum and magnesium components		
Corrosion protection	All steel parts are 100% dual-side zinc-galvanized. (12-year limited warranty against corrosion perforation)		
CAPACITIES:			
	quattro		
Engine oil	11.3 qt.	10.7 liter	
Fuel tank	16.6 gal.	63 liter	
Cooling system	12.9 qt.	12.2 liter	
EXTERIOR DIMENSIONS:			
	quattro		
Wheelbase	104.5 in.	2654 mm	
Track: front / rear	59.8 in.	1518 mm / 59.9 in.	1520 mm
Overall length	180.0 in.	4573 mm	
Overall width / with mirrors	70.0 in.	1778 mm / 75.2 in.	1911 mm
Height (unloaded)	54.8 in.	1391 mm	
Ground clearance (loaded)	4 in.	102 mm	
Curb weight: man. / auto.	4211 lbs.	1910 kg / 4266 lbs.	1935 kg
Drag coefficient: Front / quattro	Cw = 0..31	Frontal Area = 2.11 sq.m.	
INTERIOR DIMENSIONS (SAE measurements):			
Seating Capacity	4		
EPA class	Compact		
Head room front / rear	37.95 in.	964 mm /	36.3 in. 922 mm based on sedan
Shoulder rm. front / rear	53.0 in.	1347 mm /	45.1 in. 1145 mm
Leg room front / rear	41.3 in.	1050 mm /	32.4 in. 823 mm
Interior vol. front / rear	42.2 cu. ft.	1195 L /	30.7 cu. ft. 869 L
Luggage Capacity	10.2 cu. ft.	289L	(83.1 total cu.ft / 2353L, incl. trunk volume)
PERFORMANCE:			
	quattro		
	Manual 6-speed	6-speed Tiptronic automatic	
0-50 mph (0-80kmh)	4.5 sec.	4.8 sec.	
0-60 mph (0-100 km/h)	5.8 sec.	6.1 sec.	
1/4 mile	14 sec.	14.2 sec.	
Top speed	Top speed is electronically limited at 155 MPH (250 km/h)		
FUEL ECONOMY:	EPA estimate		
	quattro		
	Manual 6-speed	6-speed Tiptronic automatic	
City	14 mpg	15 mpg	
Highway	21 mpg	23 mpg	
Combined	17 mpg	18 mpg	
FUEL ECONOMY:	Canadian Estimate		
	Manual 6-speed	6-speed Tiptronic automatic	
City	16.2 liters/100km	15.5 liters/100km	
Highway	10.2 liters/100km	9.5 liters/100km	

Audi S4 Cabriolet

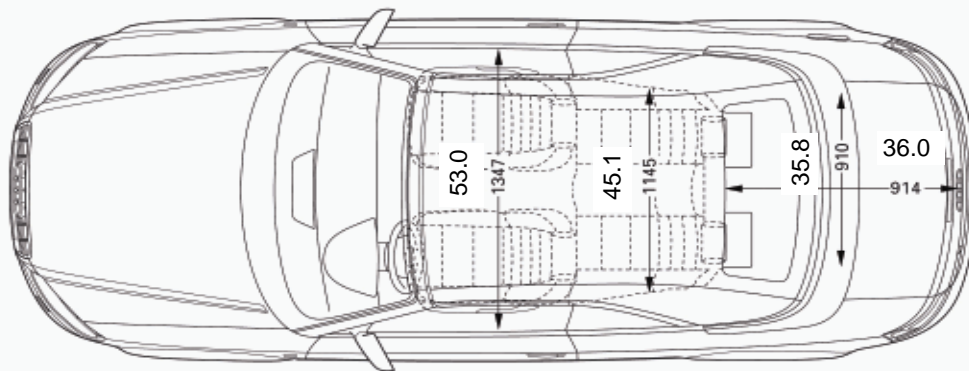
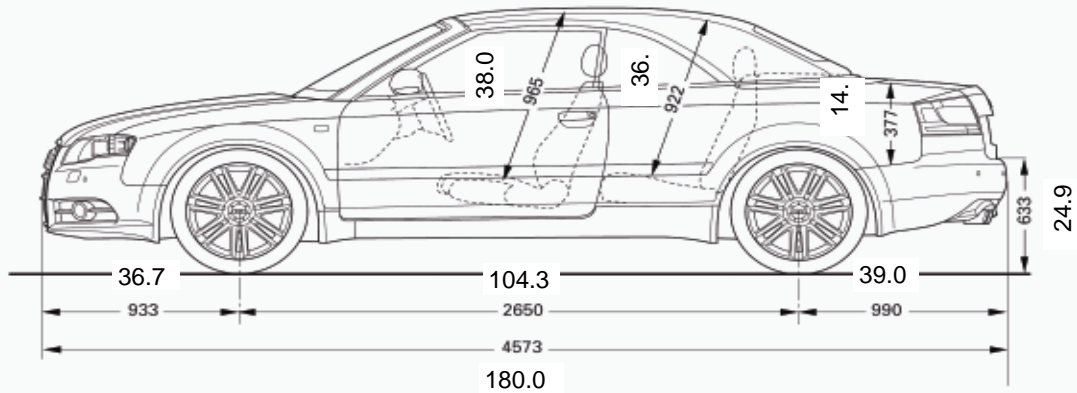
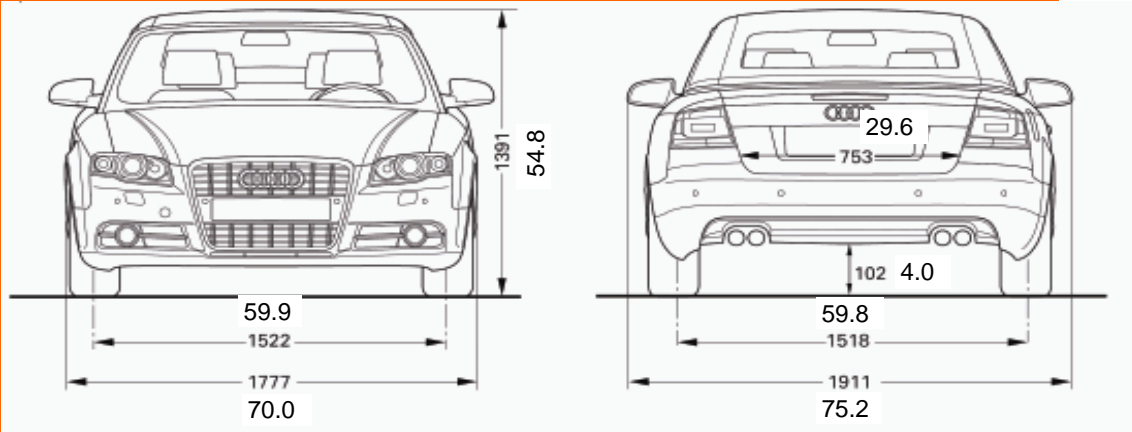

Audi of America
2008 S4 Cabriolet
Order Guide - Options



MODELS				
Body Style	Engine	Transmission	Retail	
2 Door Cabriolet (50-State)	4.2L, 8 CYL., 5V, 340 HP	6-Speed quattro	\$56,775	
		Auto Tiptronic quattro	\$57,975	

PACKAGES		Retail	Dealer Invoice
Convenience Package HomeLink, Rain and Light Sensor with "Coming Home", Auto-dimming Exterior Mirrors, Auto-Dimming Interior Mirror with Compass, 18" quattro GmbH 7 double-spoke wheel (235/40 R18), Bose premium sound with AudioPilot, Memory for Driver Side Seat Adjustment and Exterior Mirror Positions, Adaptive Front Lighting System, Bluetooth phone prep		\$2,625	

STAND ALONE OPTIONS		
Heated Rear Seats (requires PPX)		\$225
iPod glove box interface (not available with PNZ or PND) (requires PPX)		\$250
Audi Navigation plus, iPod interface, color trip computer (not available with UF1 or PND) (requires PPX)		\$1,950
Audi Navigation plus, glove box 6-CD changer, color trip computer (N/A w/ UF1 or PNZ) (requires PPX)		\$1,950
Audi parking system, rear (requires PPX)		\$350
Carbon Fiber Beltline Trim (not available with 5TZ) (requires PPX)		\$400
Gray Birch Beltline Trim (requires PPX)		\$400
Northeast Trading Region Emission Requirements		N/C
California Emission Requirements		N/C

ONE OF THE FOLLOWING OPTIONS REQUIRED ON ALL ORDERS		
Front license plate holder (for States which require front license plates)		N/C
Front grille filler panel (grille filler with chrome strips for States without front license plate requirement)		N/C

OTHER CHARGES		
Metallic and pearl effect paints		\$475
Premium paint charge		\$750
Gas Guzzler Tax (Manual Transmission Only - 8HE549) Subject to Change		\$1,700
Gas Guzzler Tax (Auto Transmission Only - 8HE54L) Subject to Change		\$1,300
Destination charge (add to all orders)		\$775

Specifications, equipment, options and prices are subject to change without notice. Some items may be unavailable when vehicle is built. Prices exclude destination charges, registration, and retail delivery charges.

Revised Date: August 17, 2007

Audi of America
 2008 S4 Cabriolet
 Order Guide - Color and Trim



Exterior Paint Codes

Interior Trim Codes

Exterior Colors	Roof Color	Upholstery Colors:
		Premium Leather Sport Seats
Brilliant Black A2PA	Black	Black w/ Silver Piping: ZM Silver w/ Black Piping: ZQ Crimson Red w/ Black Piping: ZU
Brilliant Red C8PA	Black	ZM / ZQ
Light Silver Metallic¹ 5BPA	Black	ZM / ZQ / ZU
Dolphin Gray Metallic¹ F5PA	Black	ZM / ZQ / ZU
Moro Blue Pearl Effect¹ P7PB	Blue	ZQ
Ibis White T9PA	Black	ZM / ZU

The following paints/trims are available on at a premium charge

Phantom Black Pearl Effect² L8PA	Black	ZM / ZQ / ZU
Sprint Blue Pearl Effect³ 5NPA	Black	ZM / ZQ

¹ Metallic and Pearl Effect Paint at Extra Cost

² Premium charge

Revised Date: August 17, 2007

Interior Component Color			
Seats / Door Inserts / Arm Rest	Dashboard Beltline Trim (unless replaced with optional trim)	Upper & Lower Dashboard	Carpet & Headliner
Black	Brushed Aluminum	Black	Black
Silver	Brushed Aluminum	Black	Black
Red	Brushed Aluminum	Black	Black